

RV102-MMNFI

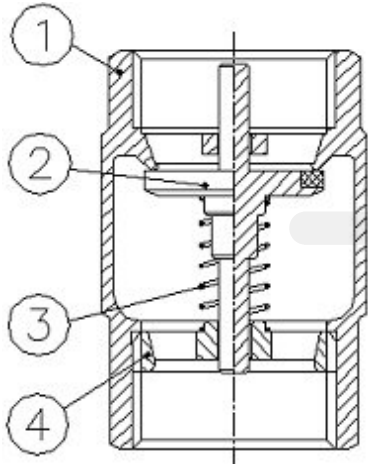
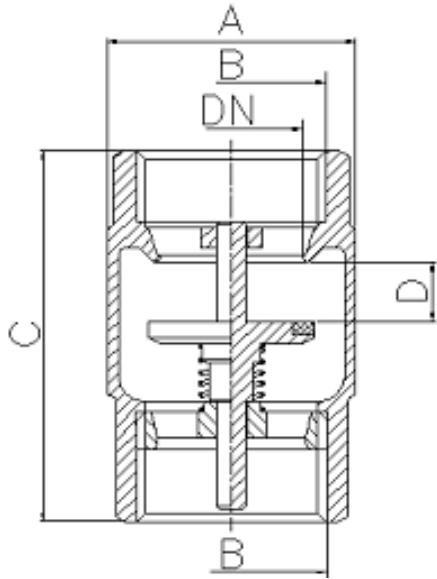

Dimensions [mm]

DN	B	ØA	C	D	bar	Weight (g)
15	1/2"	30	50	7,5	25	110
20	3/4"	36,5	57	8,5	25	180
25	1"	43	65	10,5	25	260
32	1 1/4"	53	70	11	18	380
40	1 1/2"	64,5	75,5	12	18	525
50	2"	79,5	81,5	14	18	800
65	2 1/2"	104	104	22	12	1660
80	3"	124	113	23	12	2365
100	4"	155	132	27	12	3935

Materials

Nr.	Bauteil / Part	Material	Oberflächenbehandlung / Surface Treatment
1	Gehäuse / Body	Messing / Brass	kugelgestrahlt / peened + machined
2	Teller / Plate	Messing / Brass + NBR	kugelgestrahlt u. vulkanisiert / peened + vulcanized
3	Dichtung / Spring	AISI 304	
4	O-Ring	Messing / Brass	kugelgestrahlt / peened + machined

DRUCKVERLUSTDIAGRAMM / HEAD LOSSES DIAGRAM

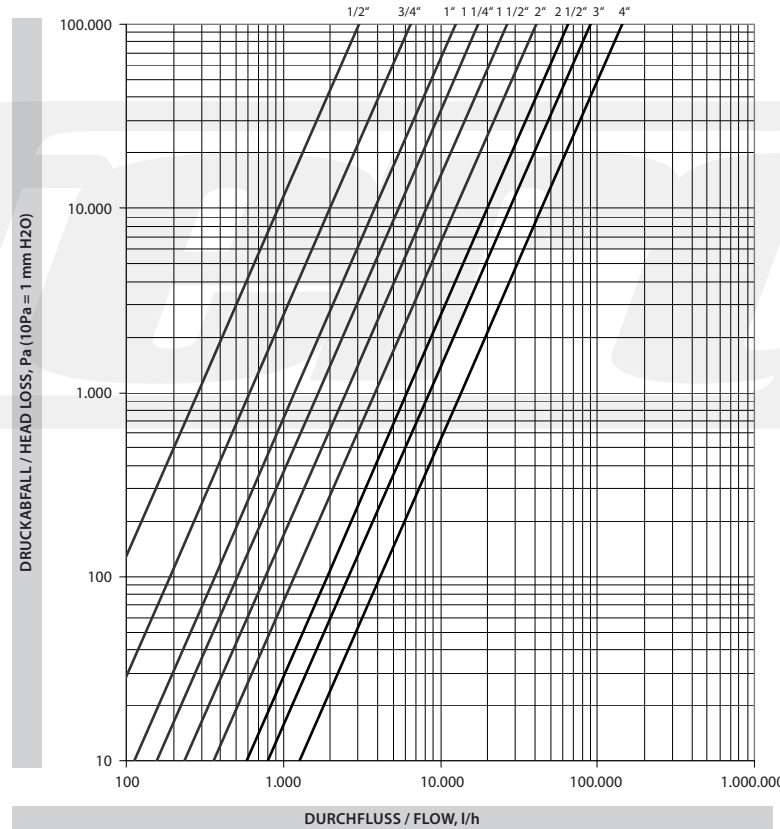

D	INCH	1/2"	3/4"	1"	1 1/4"	1 1/2"	2"	2 1/2"	3"	4"
Kv	m³/h	3,02	6,49	12,56	17,52	26,41	40,82	65,29	89,56	143,25

- D**
- Monoblock-Rückschlagventil
 - Messing (warmgeschmiedet nach EN 12165)
 - Gewindeanschluss nach ISO 228/1
 - Betriebstemperatur für:
 - Luft: -20 ... +110°C
 - Wasser: 0 ... + 90°C
 - Gas: -20 ... + 60°C
 - Mindestöffnungsdruck: 0,04 bar
 - Eibaulage: beliebig

- E**
- Monoblock check valve
 - Hot-forging brass according to EN 12165
 - Female gas threads according to ISO 228/1
 - Temperature range:
 - Luft: -20 ... +110°C
 - Wasser: 0 ... + 90°C
 - Gas: -20 ... + 60°C
 - Minimum starting pressure: 0,04 bar
 - Multipositional setting up



RV102-MMNFI